

APS300/302RDx SERIES:



300 Watts Dual Output Models

- 6.00 x 4.00 x 1.50" U-Frame Package
- 7.00 x 4.00 x 1.60" End-Mount Fan Package
- 6.00 x 4.00 x 2.00" Top-Mount Fan Package

Features:

- APS302 models are Universal AC Input (90~264 VAC) with Active PFC for EN61000-32- Class D Compliance
- APS300 Models are Auto-Ranging Input (90~132 / 180~264 VAC) with Passive PFC for EN61000-3-2 Class Compliance
- Low Profile for 1U High Applications
- Power Good & Fan Fail Functions
- 12V Aux Fan Output
- International Safety Approvals
- 2 Year Warranty

INPUT:

Input Voltage	APS302 Models = 90~264 VAC (Universal) APS300 Models = 90~132/180~264 (Autoranging)
Input Frequency	47-63Hz
Inrush Current	35A @ 115 / 70A @ 230 VAC Cold Start
Input Current	8A @ 100 VAC / 4A @ 200 VAC (max)
Input Protection	Single Fuse - 8A / 250VAC
Hold-Up Time	20ms @ 80% Load
Leakage Current	<1500 μ A @ 240 VAC Maximum
Power Factor	APS 302 = EN61000-3-2 Class D Compliant APS300 = EN6100-3-2 Class A Compliant

OUTPUT:

Adjustment Range	\pm 5%
Minimum Load	10% to maintain Regulation
Regulation	\pm 5% max
Ripple & Noise	\pm 1% typ. pk-pk @ 20MHz
Overload Protection	110-140% of max power (Hiccup Mode)
Over Voltage	Latching before 130% of nominal
Short Circuit Protection	Trip without damage & auto-recovery
Transient Response	recovers <500 μ s following a 50% load change
Overshoot	Turn-on & off overshoot < 5% over nominal voltage
Turn-On Delay	1 Second maximum at 120VAC

STATUS & CONTROL:

Power Supply On	Green LED on PCB
Fan Output	12 VDC @ 300mA
Fan Fail	High = Failure (15V/5mA Sink Current)

GENERAL:

Efficiency	75% minimum (230 VAC / Full Load)
Operating Temperature	0-70°C, derate linearly to 50% Load at 70°C
Storage Temperature	-20°C to +85°C
Over-Temp Protection	>85°C Shutdown (Ambient)
Cooling	22 cfm airflow required for full load
Operating Humidity	5-90% RH, Non-Condensing
Vibration	5 ~ 50 Hz, acceleration 7.35 m/s*s on X,Y and Z Axis
MTBF	>100k Hrs (according to MIL-HBK-217F) at 30°C

EMC:

Electrostatic Discharge	EN61000-4-2, \pm 4KV Contact / \pm 8KV Air Discharge
Radiated Susceptibility	EN61000-4-3, 26-1000MHz, 10V/M, 80% AM
EFT / Bursts	EN61000-4-4, \pm 2KV
Surges	EN61000-4-5, \pm 2KV Line-Earth, \pm 1KV Line-Line
Conducted Immunity	EN61000-4-6, 0.15-800MHz, 10V, 80% AM
Voltage Dips	EN61000-4-10, 95% Dip & 10ms, 30% Dip & 500ms
Voltage Interruptions	EN61000-4-11, 95% reduction, 5s
Fluctuations & Flicker	EN61000-3-3

APPROVALS:

Emissions	EN55022 "B", FCC Part 15 Subject J Class B
Safety Approvals	UL/cUL 60950-1 CSA22.2 No. 60950-1 TUV EN60950-1 CB IEC60950-1 CE Mark (LVD)

APS300/302RDx SERIES:

Output Specifications:		V1 out	22 cfm Airflow	Convection Cooled	V2 out	22 cfm Rating	Convection Cooled	Maximum Power Airflow	Convection
Universal AC Input with Active PFC Models:	Auto-Ranging AC Input with Passive PFC Models								
APS302RDx-0512	APS300RDx-0512	+5 VDC	30.00 A	15.00 A	+12 VDC	16.67 A	10.42 A	250 Watts	125 Watts
APS302RDx-0524	APS300RDx-0524	+5 VDC	30.00 A	15.00 A	+24 VDC	8.33 A	5.20 A	250 Watts	125 Watts
APS302RDx-0548	APS300RDx-0548	+5 VDC	30.00 A	15.00 A	+48 VDC	4.16 A	2.60 A	250 Watts	125 Watts
APS302RDx-1224	APS300RDx-1224	+12 VDC	16.67 A	12.50 A	+24 VDC	8.33 A	6.25 A	300 Watts	150 Watts

• Replace "x" with the options below to designate preferred mechanical package:

U = U-Frame Package F = Top-Mount Fan E = End Mount Fan

- Consult APS for any Output Voltage within the specified Factory Setpoint Ranges above (All safety approvals are maintained)
- Standard Connections are Terminal Block. Add the Suffix "M" to designate Molex type connectors.
- (CN2) Howder Terminal block Part No. HB-95-7P or Mating Molex Part No. 09-91-1600 (16 pin).
- (CN1) Mating JST XHP-3 or equivalent (CHYAO SHIUNN JS-2001-03); Mating Pins: JST SXH-002T-P0.6 FOR AWG 30 to 26.
- (FAN2) Fan driver connector: Mating connector is a Molex P/N 22-01-1022 (2 pins 0.98 pitch) or equivalent with Series 2759 or 5159 terminals.
- Mounting Inserts: 8 Places M4X0.7. Maximum Penetration 4mm sees outline drawing for location.

U-FRAME PACKAGE (OPTION "U"):

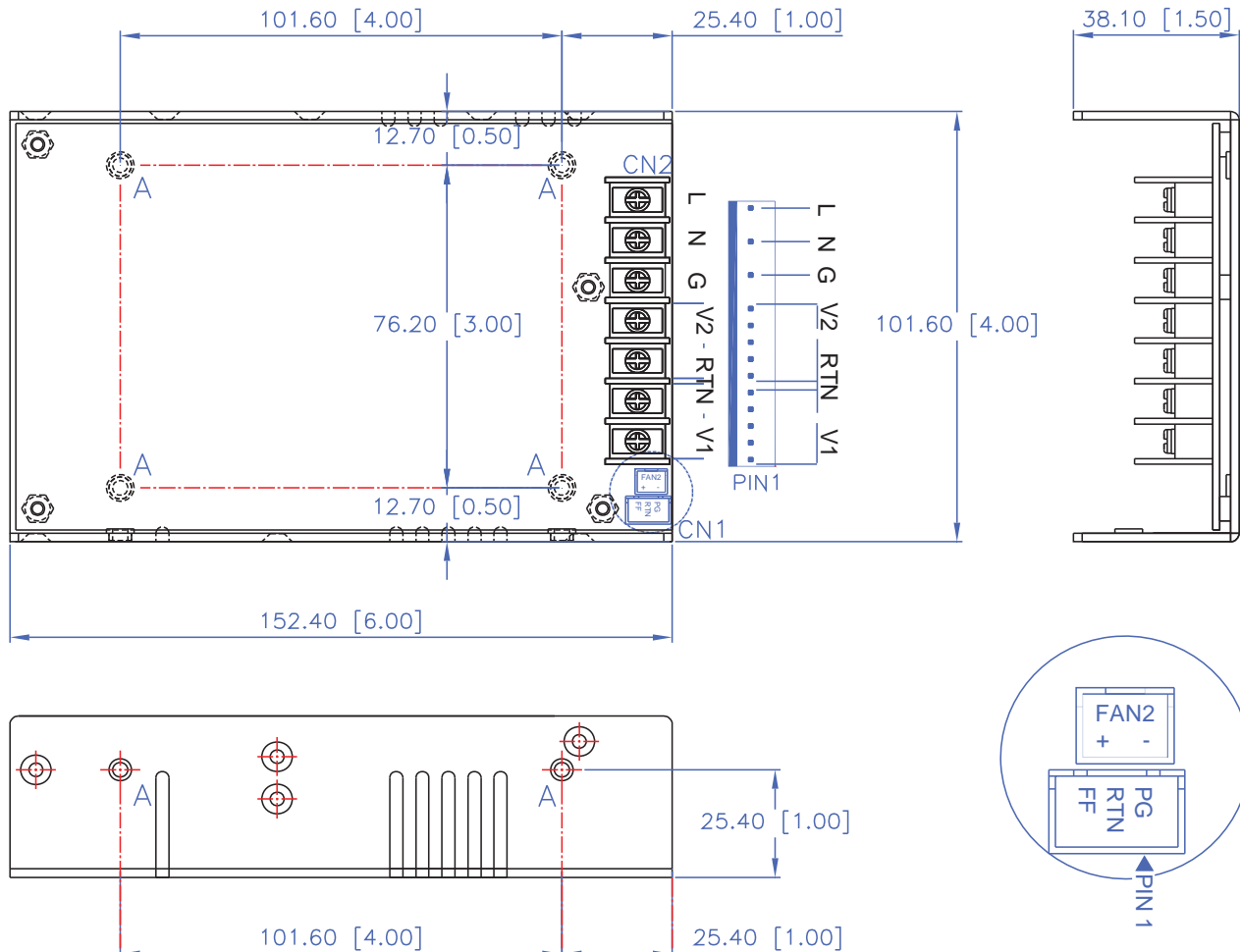

APS300/302RDx SERIES:

SEE U-FRAME PACKAGE FOR PIN ASSIGNMENTS:

**TOP-MOUNT FAN PACKAGE
(OPTION "F"):**

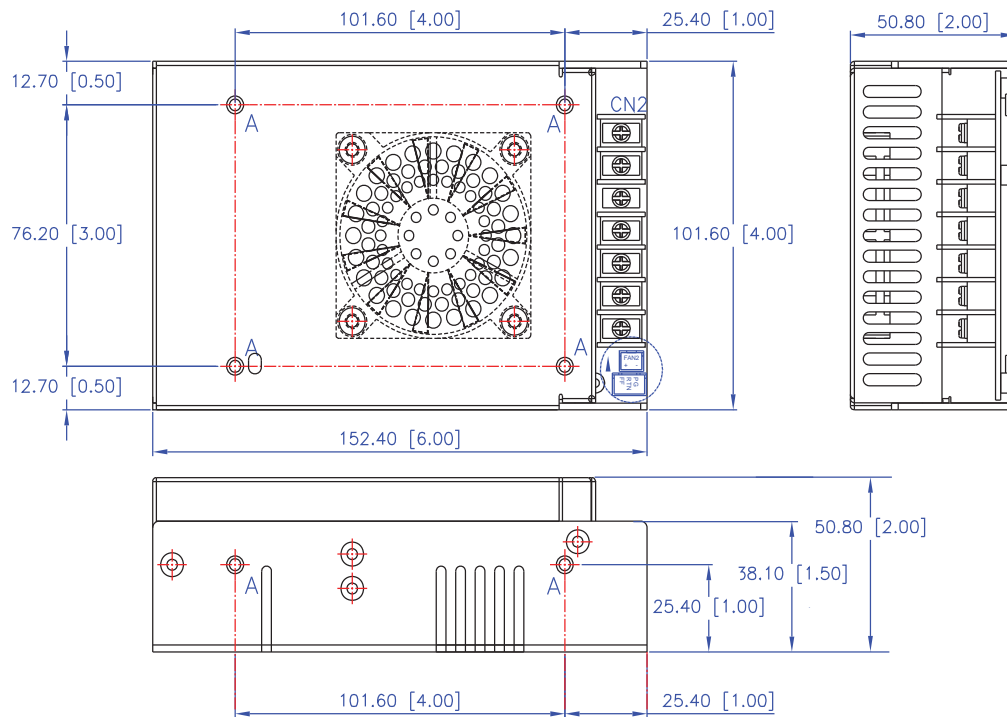

**END-MOUNT FAN PACKAGE
(OPTION "E"):**

